



# Technical Notes on Brick Construction

Brick Industry Association 11490 Commerce Park Drive, Reston, Virginia 20191

18A  
REVISED

December  
1991

## MOVEMENT DESIGN AND DETAILING OF MOVEMENT JOINTS PART II

**Abstract:** Expansion joints are used in brick masonry to allow for movement and avoid cracking. This *Technical Notes* defines the different types of movement joints used in building construction. Equations are given to determine the proper size and spacing of brick expansion joints. Examples show the proper placement of expansion joints to avoid cracking of brick masonry. Information is also included on bond breaks, bond beams and flexible anchorage.

**Key Words:** brick, differential movement, expansion joint, flexible anchorage, sealants.

### INTRODUCTION

Because all materials in a building experience changes in volume, a system of movement joints is necessary to allow these movements to occur. Failure to permit these movements may result in cracks in brickwork as discussed in *Technical Notes* 18. The type, size and placement of movement joints is critical to the proper performance of the building. This *Technical Notes* defines the different types of movement joints and discusses the proper design of expansion joints within brick masonry buildings. Details of expansion joints are provided for loadbearing and non-loadbearing applications.

### MOVEMENT JOINTS

There are various types of movement joints in buildings: expansion joints, control joints, building expansion joints, and construction joints. Each type of movement joint is designed to perform a specific task, and they should not be used interchangeably.

An *expansion joint* is used to separate brick masonry into segments to prevent cracking due to changes in temperature, moisture expansion, elastic deformation due to loads, and creep. Expansion joints may be horizontal or vertical. The joints are formed of highly *elastic* materials placed in a continuous, unobstructed opening through the brick wythe. This allows the joints to close as a result of an increase in size of the brickwork. Expansion joints must be located so that the structural integrity of the brick masonry is not compromised.

A *control joint* is used in concrete or concrete masonry to create a plane of weakness which, used in conjunction with reinforcement or joint reinforcement, controls the location of cracks due to volume changes resulting from shrinkage and creep. A control joint is usually a vertical opening through the concrete masonry wythe and may be formed of *inelastic* materials. A control joint will open rather than close. Control joints must be located so that

the structural integrity of the concrete masonry is not affected.

A *building expansion (isolation) joint* is used to separate a building into discrete sections so that stresses developed in one section will not affect the integrity of the entire structure. The isolation joint is a through-the-building joint.

A *construction joint (cold joint)* is used primarily in concrete construction where construction work is interrupted. Construction joints are located where they will least impair the strength of the structure.

### Expansion Joints

Although the primary purpose of expansion joints is to accommodate movement, the joint must also resist water penetration and air infiltration. Figure 1 shows various ways of forming vertical expansion joints. A copper waterstop, a premolded foam pad or a neoprene pad may be included as a barrier to keep mortar or other debris from

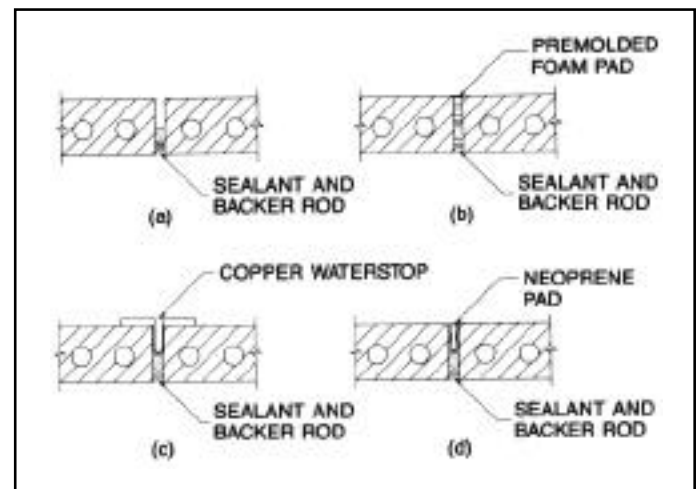

Vertical Expansion Joints  
FIG. 1

clogging the joint and aids in resisting water penetration. Fiberboard and other similar materials are not suitable for this purpose because they are not highly compressible and, after being compressed, they will not expand to their original size.

When placing expansion joints in brick, materials such as mortar or joint reinforcement should not bridge the expansion joint. If this occurs, movement will be restricted and the expansion joint will not perform as intended. Expansion joints should be formed as the wall is built, as shown in Fig. 2.

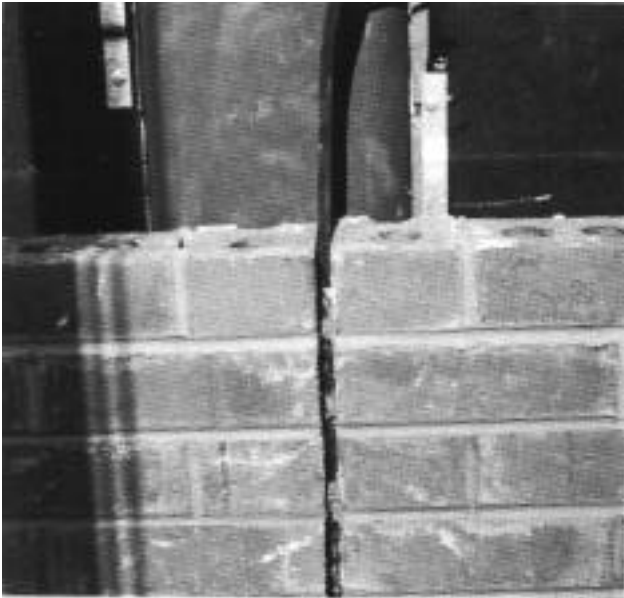

Expansion Joint Construction  
FIG. 2

Sealants are used on the exterior side of the expansion joint to act as a seal against water and air penetration. Many different types of sealants are available, although those which exhibit the highest movement capabilities are best. Elastomeric sealants must be highly elastic, resistant to weathering (ultraviolet light) and have high bond to adjacent materials. These elastomeric sealants are classified by three generic types: urethanes, silicones and polysulfides. Sealant manufacturers should be consulted for the applicability of their sealants as expansion joint materials. The sealant should conform to ASTM C 920 Specification for Elastomeric Joint Sealants. Many sealants require a primer to be applied to the masonry surface to ensure adequate bond. Compatibility of the sealant with adjacent materials such as flashings, metals, etc. must be taken into consideration.

A backer rod, which is a circular foam rod, is used behind the sealant to keep the sealant at a constant depth and provide a surface to tool the sealant against. The sealant must not adhere to the backer rod. The depth of the sealant should be approximately one-half the width of the expansion joint, with a minimum sealant depth of 1/4 in. (6 mm). Increased resistance to water and air infiltration can be achieved by designing a two-stage joint as shown in Fig. 3. A two-stage joint is often used in a rain

screen wall providing a vented or pressure-equalized joint. The space between the sealants must be vented to allow drainage. This is achieved by leaving a hole or gap in the sealant at the top and bottom of the joint.

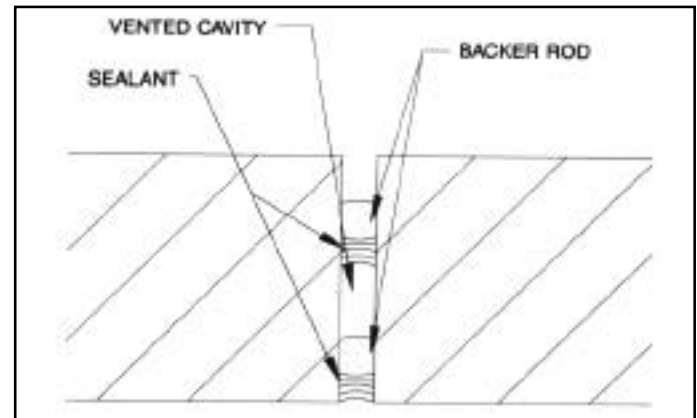

Two-Stage Expansion Joint  
FIG. 3

### Vertical Expansion Joints

**Spacing of Vertical Expansion Joints.** No single recommendation on the positioning and spacing of expansion joints can be applicable to all structures. Each building should be analyzed to determine the extent of movements expected within that particular structure. Provisions should be made to accommodate these movements and their associated stresses by a series of expansion joints. Generally, spacing of expansion joints is determined by considering the amount of expected wall movement and the size of compressibility of the expansion joint and expansion joint materials.

Unrestrained expansion of the brickwork may be estimated by the following formula:

$$m_u = (k_e + k_f + k_t T) L \quad \text{Eq. 1}$$

where:

$m_u$  = total unrestrained movement of the brickwork, in.

$k_e$  = coefficient of moisture expansion, in./in.

$k_f$  = coefficient of freezing expansion, in./in.

$k_t$  = coefficient of thermal expansion, in./in./°F

$T$  = temperature change in brickwork, °F.

$L$  = length of wall, in.

The design value of the coefficient of moisture expansion for clay masonry is usually 0.0005 in./in. The coefficient for thermal expansion is 0.000004 in./in./°F. The coefficient of freezing expansion is taken as 0.0002 in./in. Freezing expansion does not occur until wall temperatures go below 14°F (-10°C). Further, the units must be saturated when frozen to cause expansion. Local conditions must be considered to determine if freezing expansion will occur, but is usually considered negligible.

Equation 1 provides an estimate of the amount of movement occurring in a wan system. In addition to the amount of movement, there are other variables which

may affect the size and spacing of expansion joints. These include wall restraint, elastic deformation due to loads, shrinkage and creep of mortar, construction tolerances and wall orientation.

The following equation relates spacing between expansion joints to total unrestrained movement of the brick work and the expansion joint width.

$$S_e = \frac{w_i e_i}{(k_e + k_f + k_t) T} 100 \quad \text{Eq.2}$$

where:

$S_e$  = spacing between expansion joints, in.

$w_i$  = width of expansion joint, in.

$e_i$  = extensibility of expansion joint material, %

The expansion joint is typically sized to resemble a mortar joint, usually 3/8 in. (10 mm) to 1/2 in. (13 mm). The maximum size of the expansion joint may depend on the sealant capabilities. Extensibility of highly elastic expansion joint materials are typically in the range of 25 % to 50%. Compressibility of backing materials can range up to 75%.

The temperature change in brickwork used in Eqs. 1 and 2 is based on mean wall temperatures. The theoretical change in temperature is equal to the maximum or minimum mean wall temperature minus the mean wall temperature at the time of installation. Although this theoretical temperature difference is precise, it is difficult to accurately predict the temperature at the time of installation, and the minimum and maximum temperatures. Therefore, it is conservative to calculate the temperature variation based on the difference between the maximum and minimum mean wall temperature.

Maximum mean wall temperatures vary from the maximum ambient air temperature to as high as 140°F (60°C) depending on wall orientation, location of insulation, color and density of the wall. Minimum mean wall temperatures will typically be close to the winter design temperature. Therefore, wall temperature differences,  $T$ , can vary from less than 50°F (10°C) to about 160°F (71°C).

As an example of the use of Eq. 2, consider a brick veneer wall which is facing south. The color of the brick is a light red and the desired size of the expansion joint is 3/8 in. (10 mm). The extensibility of the sealant is 50%. Assuming appropriate values and no freezing expansion, Eq. 2 would give the following expansion joint spacing:

$$\begin{aligned} S_e &= \frac{(0.375 \text{ in.}) (50)}{[(0.0005 + 0.000004 (100^\circ\text{F}))] 100} \\ &= 208 \text{ in. or } 17\text{ft-}4 \text{ in. (5.3 m)} \end{aligned}$$

Therefore, the maximum spacing for vertical expansion joints in a straight wall would be 17ft-4 in. (5.3 m). This spacing does not take into account window openings, corners or other material properties that may reduce the spacing of the expansion joints. The extent to which precautions should be taken to prevent masonry cracking will depend upon the intended use of the structure and its

exposure. In most instances it is desirable to be conservative, but it may be economically desirable to exceed the maximum spacing as a calculated risk. An example would be when calculations show a need for expansion joints every 18 ft (5.5 m) but the expansion joint spacing is set at 20 ft (6.1 m) to match the spacing of the structural columns. Generally, vertical expansion joints should not exceed 30 ft (9.1 m) in walls without openings.

### Placement of Vertical Expansion Joints

The actual location of vertical expansion joints in a structure is dependent upon the configuration of the structure as well as the expected amount of movement. In addition to adequately placing expansion joints within long walls, consideration should be given to placement of expansion joints at: corners, offsets, openings, wall intersections, changes in wall heights and parapets.

**Corners.** Walls perpendicular to one another will expand towards their juncture, typically causing distress at the first head joint on either side of the corner (Fig. 4a). Expansion joints should be placed near corners to alleviate this stress. It is often not aesthetically pleasing to place expansion joints at the corner, although this is the best location. In such instances, an expansion joint should be placed within 10 ft (3.0 m) of the corner in either wall, but not necessarily both. The spacing of expansion joints

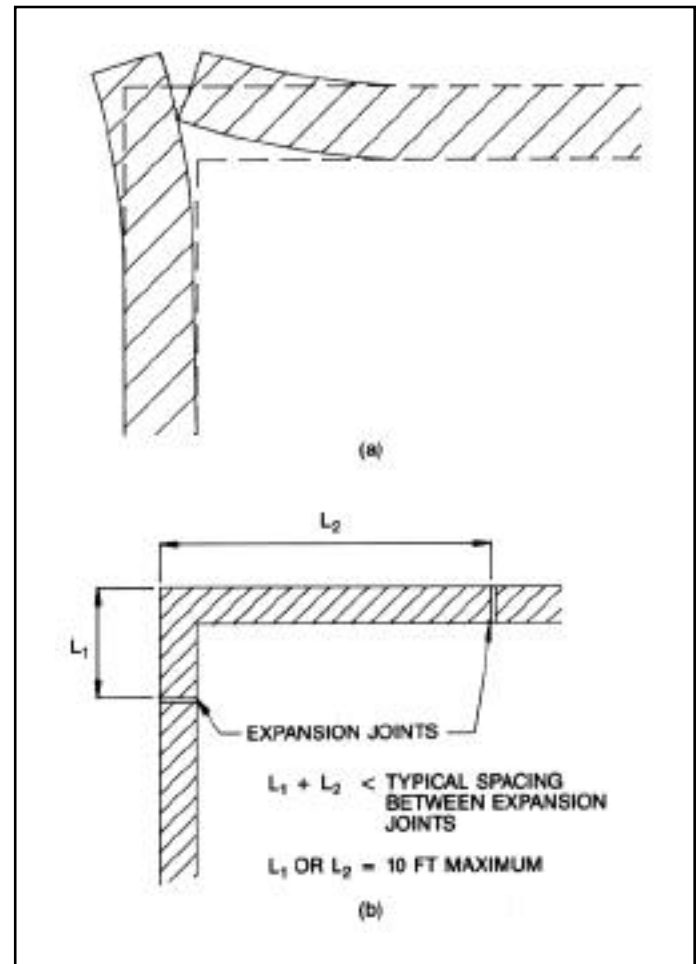

Expansion Joints at Corners  
FIG. 4

around a corner should not exceed the spacing of expansion joints in a straight wall (Fig. 4b). For example, if the spacing between vertical expansion joints on a straight wall is 25 ft (7.6 m), then the spacing of expansion joints around a corner could be 10 ft (3.0 m) on one side of the corner and 15 ft (4.6 m) on the other side. Joint reinforcement may be added around wall corners to provide added tensile strength to the corner. Joint reinforcement should not bridge the expansion joint.

**Offsets and Setbacks.** Parallel walls expand towards the offset rotating the short masonry leg, or causing cracks within the offset (Fig. 5a). Expansion joints should be placed at the offset to allow the parallel walls to expand (Fig. 5b).

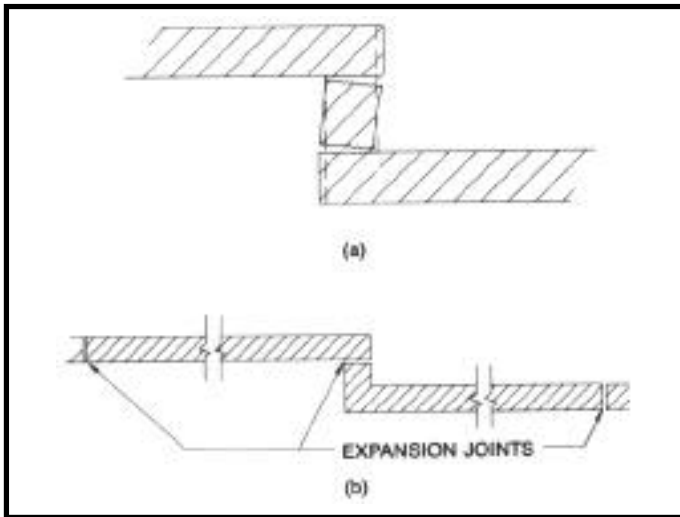

Expansion Joints at Offsets  
FIG. 5

**Openings.** Cracks often appear at window and door openings when the spacing between expansion joints is too large. In structures containing punched windows and door openings, more movement occurs above or below the openings. Less movement occurs along the line of windows since there is less masonry. This differential movement may cause cracks which emanate from the corners of the opening as in Fig. 6. This pattern of cracking does not exist in ribbon window structures.

Window and door openings weaken the wall yet act as "natural" expansion joints. It is often desirable to locate vertical expansion joints along the edge or jamb of the opening. In cases where the masonry above an opening is supported by shelf angles attached to the structure, a vertical expansion joint can be placed alongside the opening, continuing through the horizontal support.

In cases where the masonry above the opening is supported by loose lintels (unattached to the structure), special detailing and construction is required. If the expansion joint runs along side the opening as shown in Fig. 7a, the loose steel lintel must be allowed to expand independently of the masonry. To accomplish this a slip plane is formed with flashing placed above and below the angle. A backer rod and sealant is placed in front of the

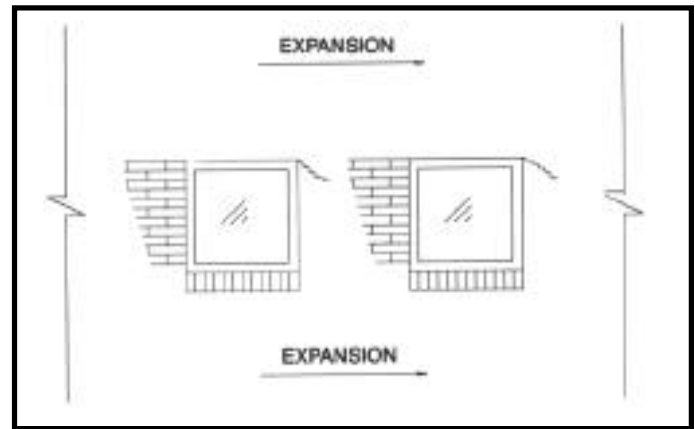

Cracking in Structure with "Punched" Windows  
FIG. 6

toe of the angle, and space left at the end of the angle. Thus, a pocket will be formed which will allow movement of the steel angle within the brickwork. If the joint cannot be built in this manner, then the vertical expansion joint should not be placed alongside the opening. An alternative may be to place it halfway between the windows. Location of the expansion joint alongside the window will influence the dead weight of the masonry bearing on the lintel. Instead of the usual triangular loading, the full weight of the masonry above the angle should be assumed to bear on the lintel. See *Technical Notes 31B* for more information on steel lintel design.

**Intersections and Junctions.** Expansion joints should be located at intersections of masonry walls and walls which serve different functions. If the masonry is not required to be bonded at the intersection, an expansion joint should be incorporated. Walls which intersect at other than right angles are also vulnerable to cracking at the intersection. It may be necessary to separate adjacent walls of different heights to avoid differential movement. This is especially true if the difference is very large. Examples are shown in Fig. 8.

**Parapets.** Parapets are exposed on three sides to extremes of moisture and temperature which may cause substantially different movement from that of the wall below. Parapets also lack the dead load of masonry above to help resist movement. Therefore, all vertical expansion joints should be carried through the parapets. Additional expansion joints may be necessary halfway between those running full height, unless the parapet is reinforced. These additional expansion joints must continue down to a horizontal expansion joint, or continue to the base of the wall.

**Aesthetic Effects.** Expansion joints are usually noticeable on flat walls of masonry buildings. There are ways to reduce the obvious demarcation. The use of a colored sealant which matches the brick helps to hide the joint. Also, mason's sand can be rubbed into new sealant to remove the sheen, making the joint blend in more. Some projects have used toothed expansion joints where the expansion joint follows the bond pattern. This type of

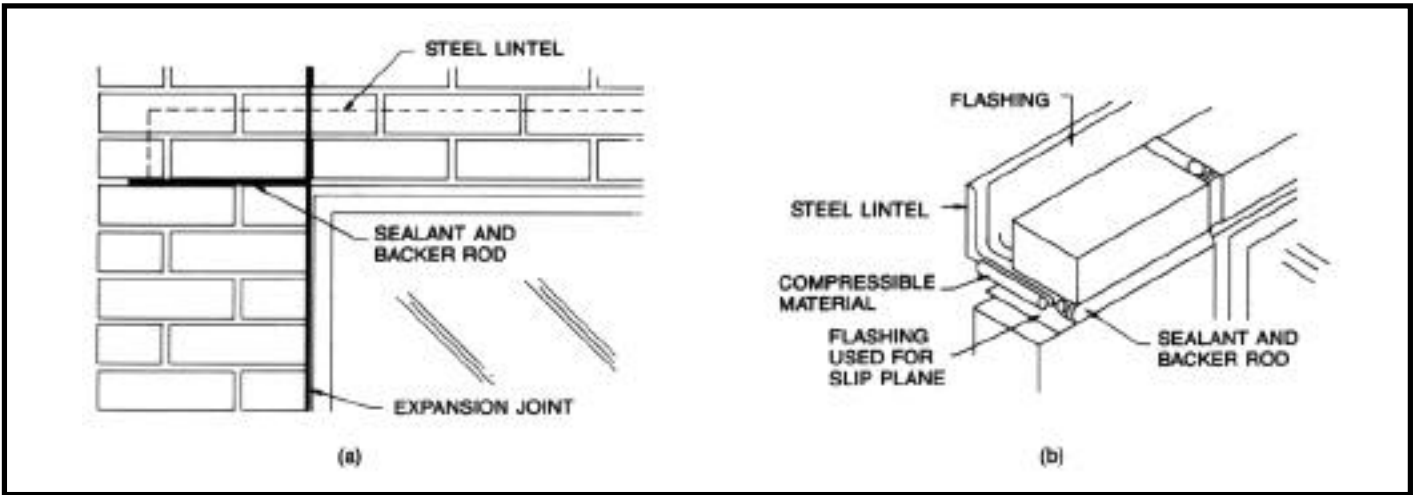

Expansion Joint at Loose Lintel  
FIG. 7

joint is not suggested because it is more difficult to keep debris out of the joint during construction which could interfere with movement. Further, most sealants do not perform well when subjected to both shear and tension.

Conversely, it may be desirable to accentuate the expansion joint instead of trying to hide it. This is possible by recessing the brickwork at the expansion joint, or using special-shaped brick units as shown in Fig. 9.

Architectural features such as quoins, recessed panels of brickwork or a change in bond pattern reduce the visual impact of vertical expansion joints. Also, expansion joints are less noticeable when located at reentrant corners.

Symmetrical placement of expansion joints on the elevation of buildings is usually most aesthetically pleasing. Further, placing the expansion joints such that wall areas and openings between expansion joints are symmetrical will reduce the likelihood of cracking.

**Other Considerations.** Location of vertical expansion joints will be influenced by additional factors. Spandrel sections of brickwork supported by a beam or floor may crack due to deflection of the support. Reduced spacing of expansion joints will permit deflection to occur without cracking the brickwork. Wall segments which have different climatic exposure conditions will respond with different



Accentuated Expansion Joint  
FIG. 9

movement. An expansion joint should separate wall areas with different exposures. Thus, an exterior wall which continues past a glass curtainwall perpendicular to the wall should have an expansion joint at the curtainwall intersection.

Movement joints must be provided in multi-wythe brick and concrete masonry walls. Expansion joints must be placed in the brick wythe and control joints must be placed in the concrete masonry, although they do not necessarily have to be aligned.

### Horizontal Expansion Joints

Horizontal expansion joints may be required when brickwork is a non-loadbearing element. Horizontal expansion joints are needed if the brick wythe is supported on a shelf angle outside the frame or used as an infill wall within the frame. Horizontal expansion joints are located at steel shelf angles by providing space beneath the angle for movement to occur. In low-rise masonry buildings (below three stories) and buildings with shear walls it is not necessary to provide horizontal relief, but differential movement should be accounted for in the tie system, win-

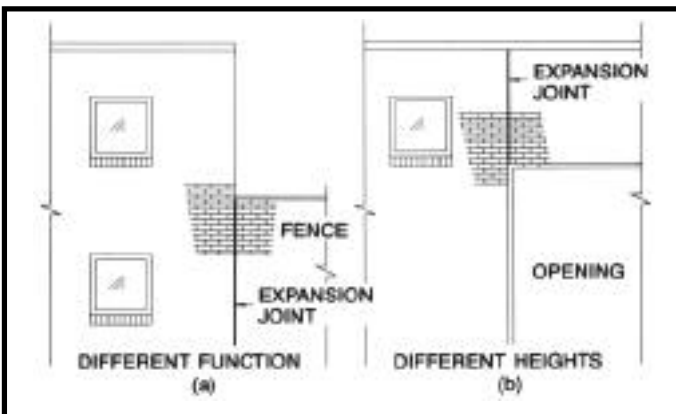

Expansion Joints at Junctions  
FIG. 8

dow details, and at the top of the wall. High-rise frame structures typically have horizontal expansion joints located at every floor level or every other floor level. Figure 10 is a typical detail of a horizontal expansion joint on a brick veneer building. Notice that a clear space or highly compressible material is placed beneath the angle, and that a backer rod and sealant are used at the toe of the angle to seal the joint.

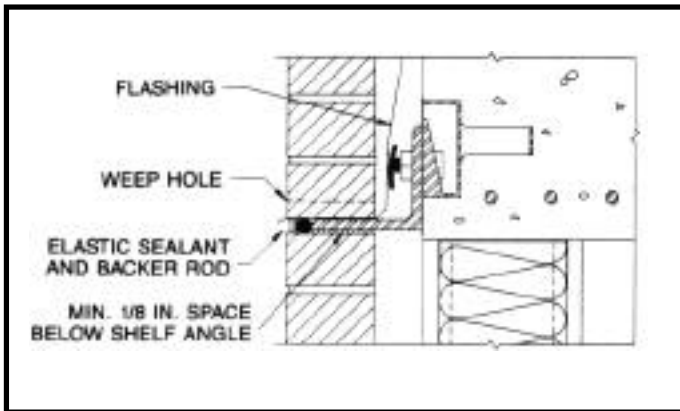

Expansion Joint at Shelf Angle  
FIG. 10

The size of the horizontal expansion joint should take into account movements of the brickwork and movements of the frame. These frame movements include both material and load induced movements, including deflection of the shelf angle. In some instances, the size of the expansion joint may get rather large and not aesthetically pleasing. An alternate detail shown in Fig. 11 allows more room for movement while providing a smaller-appearing joint. The special-shaped brick unit could also be placed below the steel angle and turned upside down.

Horizontal expansion joints are suggested when brick is used as an in still material within the frame of the structure. Expansion joints must be provided between the top course of masonry and the member above. Deflections of the frame should be considered when sizing the expansion joint.

Shelf angles are required by model building codes in most locations especially those areas of high seismic risk. They are advisable in buildings with a flexible structural frame and are recommended when the backing is steel studs.

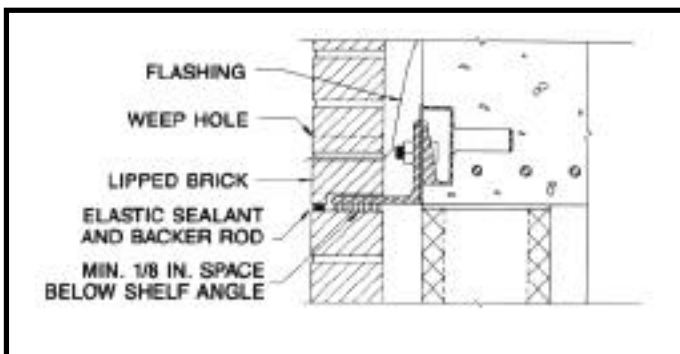

Alternate Expansion Joint Detail  
FIG. 11

## BOND BREAKS

Concrete and concrete masonry have moisture and thermal movements which are considerably different than those of brick masonry. Also, floor slabs and foundations are usually under different states of stress due to loading than are walls. Therefore, it may be important to separate these elements by bond breaks such as building paper or flashing. With bond breaks between foundations and walls; between slabs and walls; and between concrete and clay masonry, each element will be able to move somewhat independently while still providing the necessary support. Typical methods of breaking bond between walls and slabs, and walls and foundations are shown in Fig. 12.

When bands of clay brick are used in concrete masonry walls, or when bands of concrete masonry are used in clay brick walls, joint cracking may result due to the difference in material properties. It may be prudent to have the bond broken between the two materials with building paper or flashing, or to provide additional movement joints to eliminate this cracking.

Breaking bond does not affect the compressive strength of the wall and generally does not affect the stability of veneer wythes. The weight of the masonry, anchorage and the frictional properties at the interface provide for stability.

When it is necessary to anchor a masonry wall to the foundation and to the roof, it is still possible to detail the walls in a manner which allows some differential movement. Such anchorage will be required for loadbearing walls subjected to high winds or seismic forces (Fig. 13).

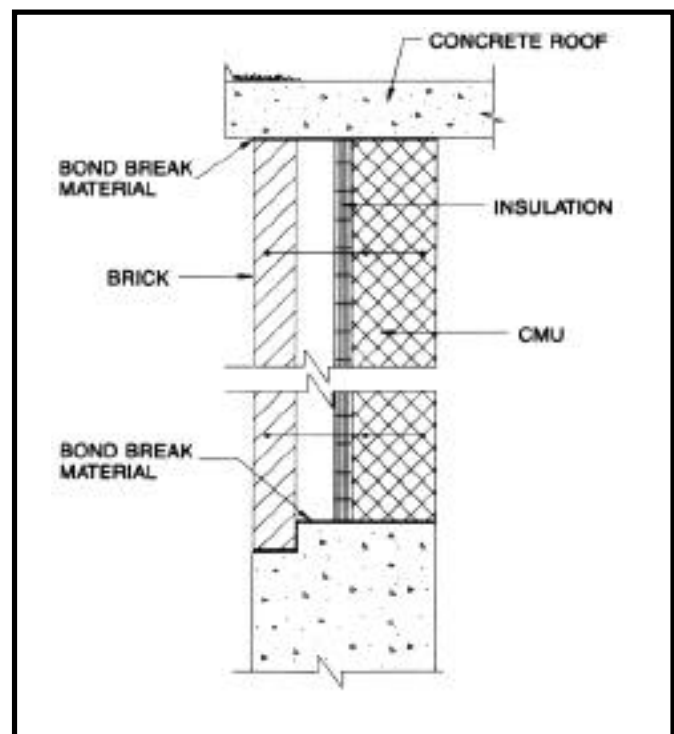

Bond Breaks in Loadbearing Cavity Wall  
FIG. 12

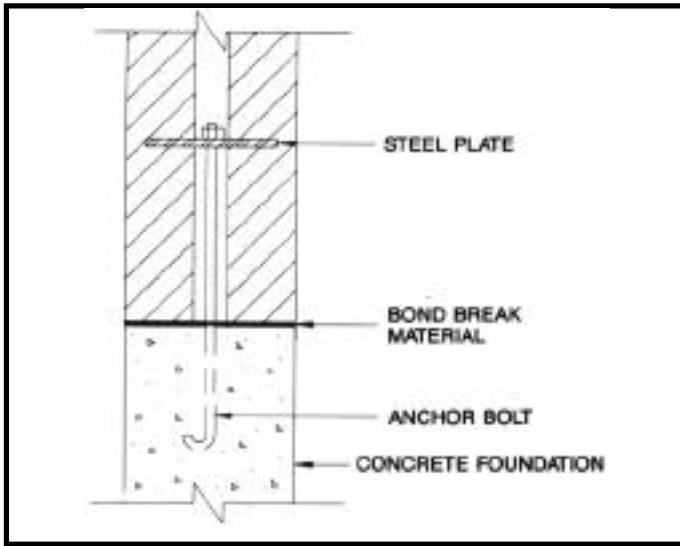

Bond Break at Foundation  
FIG. 13

height of 100 ft (30.5 m) provided the building has shear walls or rigid structural frames with stiff backing materials. For such a system, the structural frame provides the walls with lateral support and carries all other vertical loads. The wall is tied to the frame by flexible anchors or adjustable ties which permit differential movement. Allowance for differential movement between the exterior brickwork and the structure is provided at any openings and at the tops of walls. Vertical expansion joints as discussed earlier must be incorporated.

**Flexible Anchorage**

Where anchors tie walls to the structural frame or the backing to provide lateral support, the anchors and ties should be flexible; i.e. resist movement perpendicular to the plane of the wall (tension and compression) but not parallel to the wall (shear). This flexibility permits differential movements between the structure and the wall. Figure 15 shows typical methods for anchoring masonry walls to columns and beams. Details of anchoring brick to the backing are shown in *Technical Notes 44B*.

**LOADBEARING MASONRY**

The potential for cracking in loadbearing masonry members is less than in non-loadbearing masonry members since compressive stresses resulting from dead and live loads help offset the effects of expansive movement. Adding reinforcement at critical sections such as parapets, points of load application and around openings to accommodate or distribute high stresses will also help control the effects of movement. Reinforcement may be placed in bed joints or in reinforced bond beams (Fig. 14). It should be noted that historically, old loadbearing structures did not have expansion joints, and did not crack. However, the walls were thicker and made of homogeneous materials as compared to structures built today.

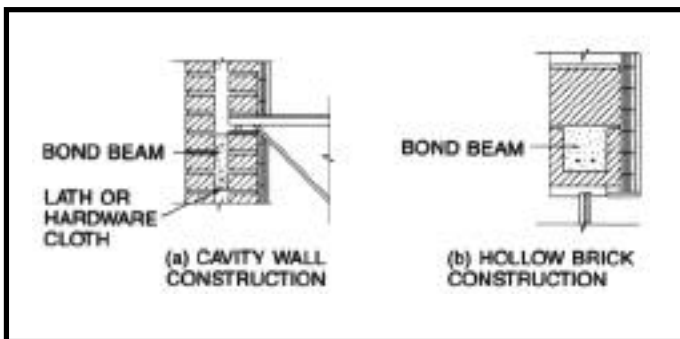

Bond Beams  
FIG. 14

**NON-LOADBEARING MASONRY**

Non-loadbearing walls are usually thinner than loadbearing walls. The exterior wythe is often thermally isolated from the building by insulation and therefore is subjected to more differential movement. For these reasons, a series of vertical and horizontal expansion joints should be designed to permit differential movement.

Brick veneer can be self-supporting up to a maximum

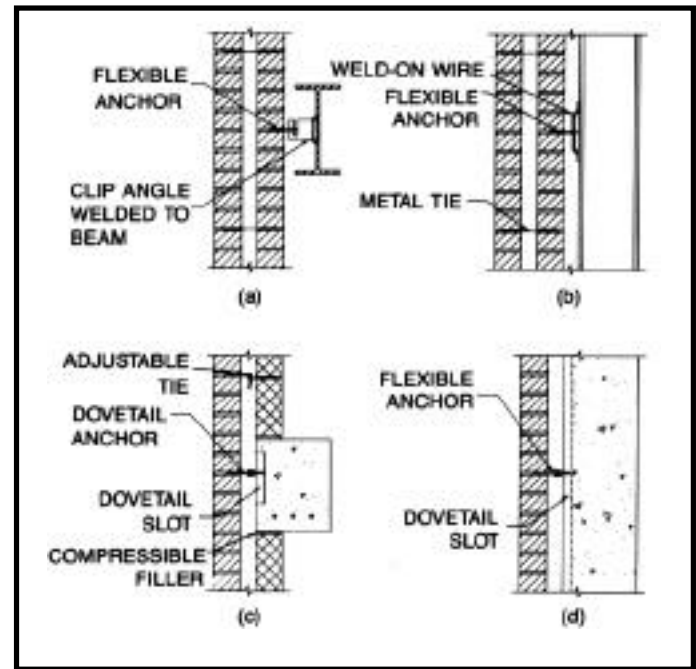

Flexible Anchorage to Beams and Columns  
FIG. 15

The size and spacing of anchors and ties are based on tensile and compressive loads induced by lateral loads on the walls. *Technical Notes 44B* lists recommended tie spacing based on application. Anchors and ties must be able to accommodate the expected movement without obstruction and without becoming disengaged.

**SUMMARY**

This *Technical Notes* defines the types of movement joints used in building construction. Details of expansion joints used in brickwork are shown. The recommended size, spacing and location of expansion joints are given. By using the suggestions in this *Technical Notes*, the pos-

sibility of cracks in brickwork can be reduced.

Expansion joints are used in brick masonry to allow for the movement generated by materials as they react to their own properties, environmental conditions and loads. In general, vertical expansion joints should be used to break the brickwork into rectangular elements which have the same support conditions, the same climatic exposure and the same through-wall construction. The maximum spacing for vertical expansion joints is 30 ft (9.1 m). Horizontal expansion joints must be placed at shelf angles supporting brick masonry.

The information and suggestions contained in this *Technical Notes* are based on the available data and the experience of the engineering staff of the Brick Institute of America. The information contained herein must be used in conjunction with good technical judgment and a basic understanding of the properties of brick masonry. Final decisions on the use of the information contained in this *Technical Notes* are not within the purview of the Brick Institute of America, and must rest with the project architect, engineer, owner, or all.

## REFERENCES

1. ASTM C 920-86, Standard Guide for Use of Elastomeric Joint Sealants, Annual Book of Standards, Vol. 04.07.
2. Beall, C., "Sealant Joint Design", Water on Exterior Building Walls: Problems and Solutions, ASTM STP 1107, T.A. Schwartz, Ed., ASTM, Phila., 1991.
3. "Building Movements and Joints", Portland Cement Association, 1982.
4. Rainger, P., "Movement Control in the Fabric of Buildings", Nichols Publishing Co., New York, 1983.
5. Szoke, S.S., Carrier, G.J., "Accommodating Movement in Brickwork", Applications and Performance of Structural Materials and Exterior Facades, ASCE Convention, Boston, MA, October 27, 1986.